



WWW.EVBGROUP.PL

EV3 AC

WALLBOX 1M



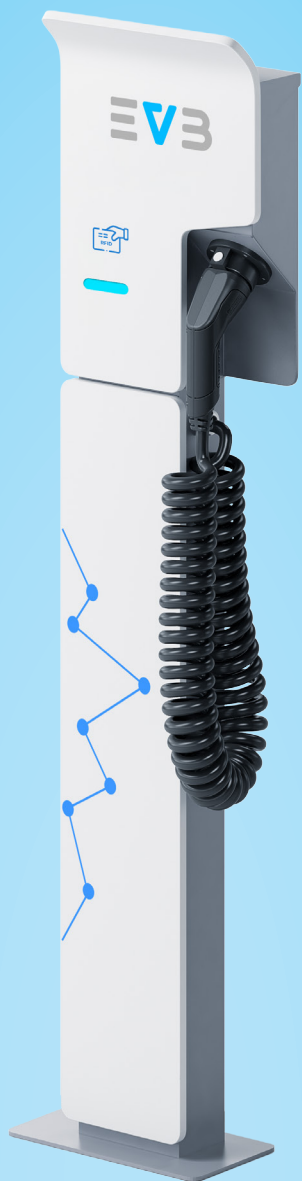

TYPE

Electric Vehicle Charging Stations EVB Wallbox 1M

MODELS / DESIGNATIONS

EVB Wallbox 1M AC / AD, AS, AM

APPLICATION

Indoor and outdoor car parks; commercial buildings, commercial buildings, multi-family buildings, private garages, parking spaces at home, industrial buildings, urban space.

DESCRIPTION

EVB Wallbox 1M AC is a small-sized indoor/outdoor station single-station equipped with a socket or plug with a straight or spiral cable up to 4.8 m long, wall-mounted or for mounting on a dedicated post.

HOUSING DESIGN

- ▶ steel (standard) in protection class I (standard) or II;
- ▶ aluminum in protection class I (standard) or II;
- ▶ any housing color;
- ▶ the front of the station is made of high-strength plastic board, 5-6 mm thick, covered with foil or screen printing (any graphics);
- ▶ universal spacing of holes on the back enables quick and easy mounting on a wall or post;

ELECTRICAL SUPPLY

- ▶ bottom; upper; back;
- ▶ Connection terminals of the station up to 10 mm²
- ▶ 3,7 kW; 7,4 kW; 11 kW; 18 kW; 22 kW with AC current

CHARGING POINT CONNECTORS

- ▶ Maximum 1 charging point:
- ▶ AC type-2 socket with flap;
- ▶ plug type-2 or type-1;
- ▶ automatic locking of the plug in the socket**
- ▶ Charging cable length up to 4.8 m:
- ▶ spiral or straight cable;

AVAILABLE ACCESSORIES

- ▶ type2 socket with flap;
- ▶ type 2 or type 1 plug;
- ▶ straight or spiral cable;
- ▶ RCD type A or B residual current protection;
- ▶ overcurrent protection type B;
- ▶ 4P contactor;
- ▶ EVSE charging process controller
- ▶ energy meter;
- ▶ MID ModBUS energy meter;
- ▶ surge protector type2;
- ▶ communication modem;
- ▶ 7 inches screen;

ADDITIONAL ACCESSORIES

- ▶ free-standing post, code: FA 10045503;
- ▶ concrete base plate, code: FP1004501;
- ▶ wall-mounted protective barrier, code: S000B02002;
- ▶ parking separator 1.6 m, code: SP00B01003;
- ▶ overvoltage protector type2, code: AP OP TYP2;
- ▶ RFID+5 card reader, code: RFID19;
- ▶ RFID card reader for operator cards**, code: RFID 1015;
- ▶ 2m power cord with 16/32A 3P+N+PE plug, code: PZ 1632;
- ▶ thermostat with 15W heater, code: TG 15W;
- ▶ wall holder for cable wrapping, code: UPK 15;
- ▶ plug type1 instead of type2, code: WTyp1;
- ▶ additional warranty of 12 months.

CHARGING SIGNALLING

- ▶ active LEDs (RGB) showing individual charging states
- ▶ 10" HD HDMI TFT screen showing the charging process

ACCESS

- ▶ plug&charge;
- ▶ key;
- ▶ RFID cards/PIN code;
- ▶ remote;
- ▶ mobile application / operator**

COMMUNICATION

- ▶ LAN/GPRS/3G/4G modem;
- ▶ OCPP 1.6 J-SON protocol (modem, central communication controller)
- ▶ operator's SIM card
- ▶ mobile application, station management system - separate offer;
- ▶ The station has access by providing an API**.

STATION PACKAGING

- ▶ cardboard unit packaging

*equipment selected depending on the version of the station.

** for public/managed stations

TECHNICAL DRAWING

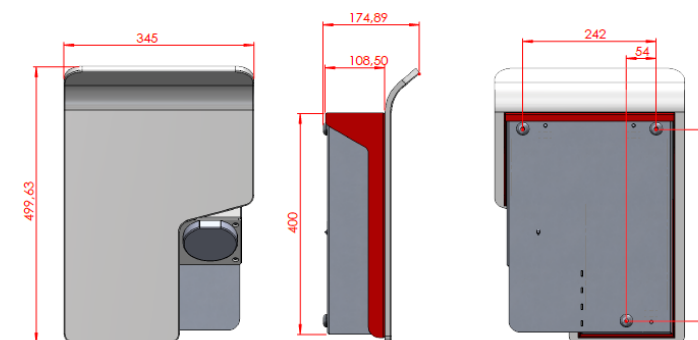

STANDARDS

EN-61851-1_2011E	Electric vehicle conductive charging system – Part 1: General requirements
EN-61851-22:2002	Electric vehicle conductive charging system - Part 22: AC electric vehicle charging station
EN 61439-1:2011	Low-voltage substations and control gear - Part 1: General rules
EN 61439-3:2012	Low-voltage substations and control gear – Part 3: Distribution board stations intended for use by persons other than the public (DBO)
EN 61439-5:2015-02	Low-voltage substations and control gear – Part 5: Sets for power distribution in public networks
EN 50274:2004	Low-voltage substations and control stations – Protection against electric shock – Protection against unintentional direct contact with hazardous live parts
EN 62208:2006	Empty enclosures for low-voltage substations and control rooms – General requirements
E 05163	Shielded low-voltage substations and switchgear – Test guidelines for arc-discharge conditions resulting from internal short circuits
EN 60695-11-10:2014-02	Fire hazard testing - Part 11-10: Test flames - 50 W flame test methods for horizontal and vertical specimen alignment
EN ISO 14040:2009	Environmental management – Life cycle assessment – Principles and structure
EN ISO 14044:2009	Environmental management – Life cycle assessment – Requirements and guidelines
EN 62196-1:2015-05	Plugs, socket-outlets, vehicle couplers and vehicle inlets – Conductive charging of electric vehicles – Part 1: General requirements
EN 62196-2:2017-06	Plugs, socket-outlets, vehicle couplers and vehicle inlets – Conductive charging of electric vehicles – Part 2: Dimensional compatibility and interchangeability requirements for a.c. plug and socket contact products
EN 62196-3:2015-02	Plugs, socket-outlets, vehicle connectors and vehicle inlets – Conductive charging of electric vehicles – Part 3: Dimensional compatibility and interchangeability requirements for d.c. and a.c./d.c. vehicle connectors with sleeve-and-pin contacts
ISO/IEC 14443	Identification cards - Proximity chips - Proximity cards
ISO/IEC 15693	Identification cards - Proximity chips - Proximity cards
EN 61000-6	Electromagnetic compatibility (EMC) - Part 6-2: Generic standards - Immunity for industrial environments

TECHNICAL SPECIFICATION OF THE HOUSING

Dimension (height/width/depth) (+/-5mm) [mm]	500/345/166
Material	Steel, aluminium
Protection class	I/II
IP/IK protection degree	54/10
Weight [kg]	3-16
Working temperature [°C]	-30 to +55
Humidity [%]	95
Noise level [dB]	<10
Installation	Wall-mounted, on a post

POWER SUPPLY SPECIFICATIONS

Cross section of supply cable [mm ²]	up to 10 mm²
Type of power supply	1xL+N+PE / 3xL+N+PE
Network layout	TN-S, TNC-S, TT
Rated switching voltage [V] (+/- 10%)	230/400
Rated insulation voltage [V]	500/690
Rated frequency [Hz]	50/60
Withstand surge voltage [kV].	8
Rated connection power [kW]	22
Rated connection current [A]	32
overvoltage protection	type 2

TECHNICAL PARAMETERS OF THE CHARGING POINTS

Socket type	Type-2
Plug type	Type-2, type-1
Charging cable length [m]	4,8
Output voltage range [V]	230/400
Charging point rated current [A] AC	up to 32
Rated power of the charging point [kW] AC	up to 22
Nominal power of the station [kW] AC	up to 22



CONTACT

MOBILE: +48 696 673 646

E-MAIL: OFFICE@EVBGROUP.PL

WWW.EVBGROUP.PL

